

Launching Crane

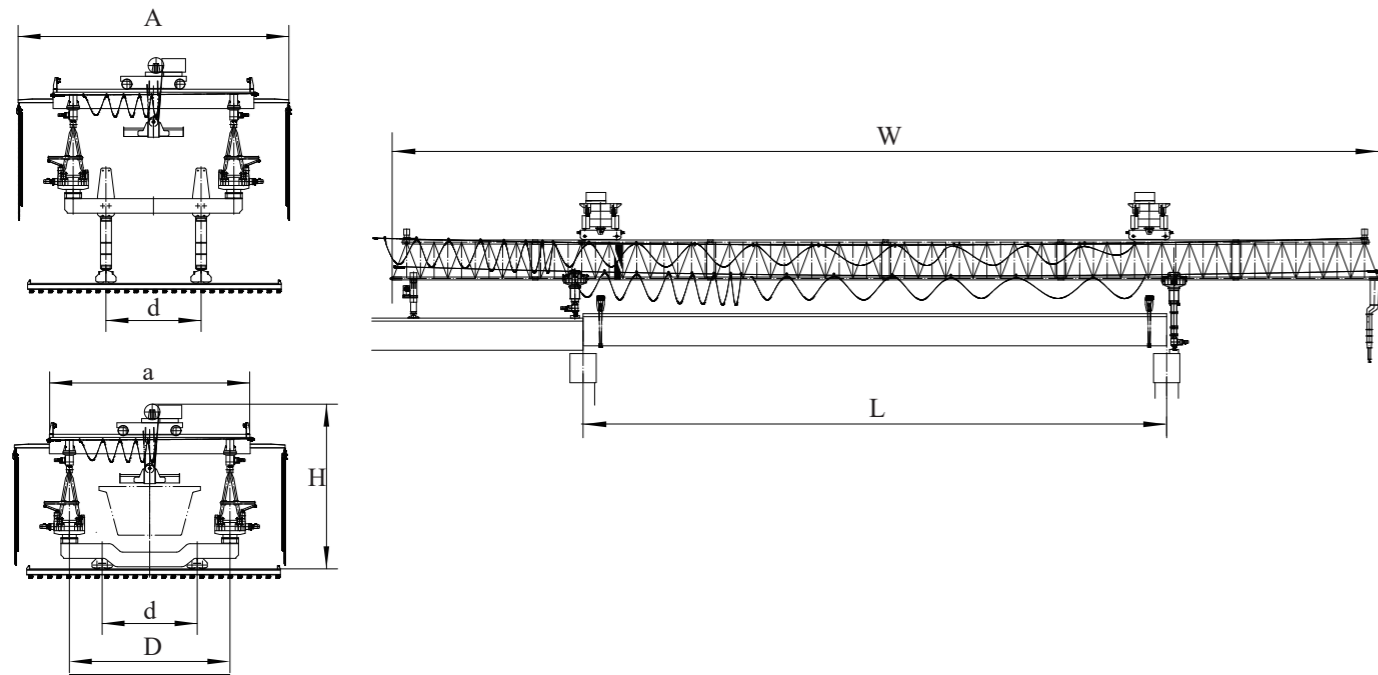

Model	JQG120/30m	JQG160/40m	JQG200/50m	JQG250/55m	JQG320/60m	JDP700/40m	
Capacity (t)	2 x 60	2 x 80	2 x 100	2 x 130	2 x 160	10 x 70	
Max. Span (m)	30	40	50	55	65	45	
Lifting Height (m)	40	40	40	40	40	40	
Lifting Speed (m/min)	0.98~1.17	0.78~1.1	0.8~1.1	0.9~1.1	0.785~0.955	0~4	
Work Duty	A3	A3	A3	A3	A3	A4	
Max. Slope of Longitudinal(%)	± 4	± 4	± 4	± 4	± 4	± 4	
Transverse Speed of Trolley(m/min)	2.16	2.3	2.3	2.3	1.985	2.3	
Min. Applicable curve Radius(m)	300	300	300	300	300	300	
Speed of Longitudinal Truss Car(m/min)	3.24	0~4	0~4	0~4	0~5.08	0~24	
Max. Slant Angle	45°	45°	45°	45°	45°	45°	
Longitudinal Speed of Main Girder Travel(m/min)	3.37	0~4	0~4	0~4	0~5.08	3.47	
Transverse Speed of Whole Crane(m/min)	2.13	2.13	2	2	2.03	2.03	
Max. Jacking of Hydraulic Front Leg(KN)	2 x 600	2 x 800	2 x 1000	2 x 1200	2 x 1600		
Max. Jacking of Hydraulic Middle Leg(KN)	2 x 600	2 x 800	2 x 1000	2 x 1200	2 x 1600		
Max. Jacking of Hydraulic Rear Leg(KN)	2 x 400	2 x 800	2 x 1000	2 x 1000	2 x 1200		
Theoretical Operation Efficiency(hour/pieces)	0.5 ~ 1.2	0.5 ~ 1.2	0.5 ~ 1.2	0.5 ~ 1.2	0.5 ~ 1.2	0.5 ~ 1.2	
Total Power(Kw)	76.1	84.7	103.3	155.6	208.2	60.4	
Total Weight(t)	≈117	≈156	≈218	≈345	≈433	≈425	
Dimension	W	53182	67632	87380	95611	114808	90740
	L	30000	40000	50000	55000	65000	40000
	D	7600	7600	7600	8000	9800	6000
	d	4500	4500	4600	4800	5600	
	A	14488	9739	9645	10300	13380	8000
	a	9500	9500	9500	10232	12000	
	H	7910	8270	8916	9943	10925	11000

Launching Crane Projects

